

Building Regulations and Historic Buildings

Balancing the needs for energy conservation with those of building conservation: an Interim Guidance Note on the application of Part L



Summary

English Heritage supports the Government's aims to improve energy efficiency, provided that the application of the new Part L is exercised in a way that does not harm the special interest of historic buildings. A sensible and reasonable approach should achieve improvements in most cases, although not always to the standards recommended in the Approved Document.

The new Part L makes it clear that the special characteristics of a historic building must be recognised. The aim of this revised part of the Building Regulations is to improve energy efficiency where practically possible, provided that this does not harm the character of the building or increase the risk of long-term deterioration to fabric or fittings.

The special interest of a historic building would be compromised if its overall appearance were to be changed or significant features or qualities were to be lost as a result of compliance with the Requirements of the new Part L. To avert a threat of this kind, a number of questions need to be considered. Could improvements be made without the need to remove or substantially alter fabric? For example, could existing windows be repaired and draughtproofed as an alternative to inserting new double glazing? Could secondary glazing be inserted? If improvements to the existing windows are not practicable, could benign improvements be made elsewhere, for example by insulating under floors or by improving the efficiency of the heating system?

An understanding of what constitutes the special interest of a historic building requires experience. Early consultation with a conservation officer is therefore strongly recommended.

Contents

<i>Summary</i>	2
<i>Glossary</i>	2
1 Preface.....	3
2 The context of the revisions to Part L.....	4
3 Historic building definitions and statutory protection.....	5
4 Principles of repair and alteration to historic buildings.....	6
5 Specific references to historic buildings in Part L.....	6
6 Meeting the Requirements of Part L.....	8
7 Historic buildings as environmental systems.....	9
8 Windows.....	12
9 Doors.....	16
10 Walls.....	16
11 Floors.....	17
12 Roofs.....	17
13 Building services.....	19
14 Forthcoming advice.....	20

References..... 21

Acknowledgements and attributions..... 22

Table: cross-references from the *Interim Guidance Note* to the appropriate sections in Part L1 of the Approved Document to the Building Regulations 2000 (2002 edition)

<i>English Heritage: Interim Guidance Note</i>	<i>Building Regulations 2000 (2002 edn): Part L1 Approved Document</i>
1 Preface	
2 The context of the revisions to Part L	
3 Historic buildings definitions and statutory protection	Page 11, 0.19; Page 21, 2.9
4 Principles of repair and alteration to historic buildings	
5 Specific reference to historic buildings in Part L	Page 11, 0.19
6 Meeting the Requirements of Part L (Improving energy efficiency in historic buildings)	Page 7, 1.11 – 1.14; Page 18, 1.58 – 1.62 Section 2
7 Historic buildings as environmental systems	Page 12, 1.3 – 1.35
8 Windows	Page 19, 2.3 a, Table 1 and Sections A1, A2 and A3
9 Doors	Page 19, 2.3 a, Table 1 and Sections A1, A2 and A3
10 Walls	Pages 20, 21, 2.6 c, 2.8 d
11 Floors	Pages 20, 21, 2.6 b, 2.8 c
12 Roofs	Pages 20, 21, 2.6 a, 2.8 b
13 Building Services	Pages 15 – 18, 1.36 – 1.57; Page 12, 1.7; Page 19, 2.3 (b – f); Page 21, 2.8 f and g

Glossary

Conservation Area Consent This is required from the local planning authority for the demolition of an unlisted building in a conservation area [Section 74 (1) of the Town and Country Planning (Listed Buildings and Conservation Areas) Act 1990]. There are however several exemptions where different consents are required, for example, listed and ecclesiastical buildings and scheduled ancient monuments.

Conservation Officer A heritage conservation specialist referred to in Planning Policy Guidance Note 15 (PPG 15, 1994), often a member of the Institute of Historic Building Conservation (IHBC), responsible for technical and other advice within a local planning authority. Local authorities which adopt a team-based approach sometimes delegate responsibilities for historic buildings, in the first instance, to a nominated planning officer within the development control section. For the purposes of this *Interim Guidance Note*, the term 'conservation officer' refers to both classes of staff, and/or specialist consultants.

DEFRA *Department of the Environment, Food, and Rural Affairs*

DETR *Department of the Environment, Transport and the Regions*

DNH *Department of National Heritage*

DoE *Department of the Environment*

DTLR *Department for Transport, Local Government and the Regions*

(Building Regulations Division was part of DTLR until 20 June 2002, after which it became the responsibility of the Office of the Deputy Prime Minister.)

Listed Building Consent Listed Building Consent is needed for the demolition of a listed building, or for its alteration or extension in any manner that would affect its

character. Listed Building Consent should normally be obtained before Building Regulations approval is sought. Carrying out unauthorised works on a listed building is a criminal offence [Planning (Listed Buildings and Conservation Areas) Act 1990 Sections 7–9]. Planning Policy Guidance Note 15 (PPG 15) provides detailed advice and guidance for those making or considering applications for Listed Building Consent.

Listed buildings: gradings Buildings are graded to show their relative architectural or historic interest:

- Grade I buildings are of exceptional interest
- Grade II* are particularly important buildings of more than special interest
- Grade II are of special interest, warranting every effort to preserve them

Sarkings Roof underlinings of board, and/or bituminous felt or modern building membranes, fixed beneath slates or tiles

Scheduled Ancient Monuments and the Building Regulations Scheduled Ancient Monuments are not subject to the Building Regulations, including Part L. 'Works carried out to a building which is included in the schedule of monuments maintained under section 1 of the Ancient Monuments and Archaeological Areas Act 1979 are exempt from the Building Regulations 2000.' (Section 3 of the Building Act 1984 and Regulation 9, schedule 2, class 1, of the Regulations refer.)

The U-value Thermal transmittance (i.e. the U-value) is a measure of how much heat will pass through one square metre of a structure when the air temperatures on either side differ by one degree. U-values are expressed in units of Watts per square metre per degree of temperature difference (W/m² deg C). [See DTLR 2001, Section 0.]

1 Preface

1.1 For whom is this guidance intended?

It is offered to those responsible for overseeing the implementation of the October 2001 edition of Building Regulations Approved Document Part L, *Conservation of Fuel and Power* (DTLR, 2001) where it affects historic buildings. Approved Document Part L came into force on 1 April 2002.

This document is intended for the following:

- building control officers
- approved inspectors
- conservation officers
- environmental health officers
- housing officers

The guidance will also be of interest to designers and others who are preparing proposals for work on historic buildings.

1.2 What is its purpose?

The *Interim Guidance Note* has been produced to help prevent conflicts between energy conservation policies enshrined in the revised Building Regulations and policies concerned with planning and the conservation of the historic environment.

1.3 Balancing conservation interests

English Heritage and other building conservation bodies support the aim of conserving fuel and power provided that it does not compromise the special interest, character and appearance of historic buildings. The right balance is needed between reducing energy use and greenhouse gas emissions, and conserving the national and local heritage. This is broadly in line with sound sustainability principles subscribed to nationally and developed locally through the Agenda 21 programme.

1.4 Sustainability

In environment terms, the continued use of existing building stock....coupled with measures to improve energy efficiency is a global priority (BS 7913: 1998). Replacing an existing building with a new one requires a considerable investment of 'embodied' energy in materials, transport and construction – typically equivalent to five or ten years of energy use to heat, light and condition the building. In global environmental terms, the balance of advantage strongly favours the retention of existing building stock, particularly when performance in terms of energy consumption in use can be improved (BS 7913: 1998). Retaining existing elements of construction in old buildings and seeking to

Box 1 Building Regulations Requirements

The Requirements of the revised Regulations are (for the most part) written in functional terms and only *adequacy* is required; in some cases a nil provision may be judged to provide it. Only in the rare cases when a Requirement is expressed in prescriptive terms could a relaxation be needed. The Approved Documents of course are entirely for practical guidance – none is mandatory. Unfortunately there is a belief (still shared by some architects and local authorities) that where the guidance is not followed some kind of 'approval' is required. This is not so.

enhance their thermal performance in benign ways, rather than replacing them, is a heritage conservation principle in line with this concept of sustainability.

Box 2 Local Agenda 21

Sustainable Development is defined as 'development that meets the needs of the present without compromising the ability of future generations to meet their own needs' (The Brundtland Report, United Nations World Commission on Environment and Development, 1987). It is not just about environmental protection. To succeed it needs to embrace all the three E's – *Economics, Equity, and Environment*.

At the Rio Earth Summit in 1992, the world's leaders formulated a plan or Agenda for the 21st century, which was taken up enthusiastically at a local level in England, and internationally, as Local Agenda 21.

This is the sustainable development initiative on which local authorities and communities have been working for a decade to turn the global plan into local policy and action.

1.5 The appropriateness of improving energy conservation in historic buildings

During the development of the revisions to Part L, discussions with the Department for Transport, Local Government and the Regions (DTLR, formerly the Department of the Environment, Transport and the Regions [DETR]) gave rise to thoughts of seeking the complete exemption of listed buildings from onerous energy conservation improvements likely to prove detrimental to their special interest. Certainly *some* historic buildings should not be altered at all, e.g. those where any change would inevitably damage their character or special interest (Staniforth and Hayes 1989). However, the majority can accommodate some improvements, even though the modern standards and techniques suggested in Part L might not be appropriate.

Box 3 'Reasonable provision'

As stated in the introductions to Parts L1 and L2, 'Approved Documents are intended to provide guidance for some of the more common building situations ... there is no obligation to adopt any particular solution ... if you prefer to meet the relevant Requirement in some other way'. DTLR therefore decided that what constituted 'reasonable provision' – the Requirement of the Statutory Instrument – was best established for each historic building on its particular merits. (The Requirements themselves are framed in very general terms, for example 'Reasonable provision shall be made for the conservation of fuel and power by limiting the heat loss through the fabric of the building'.)

1.6 Energy conservation measures

These measures should not be applied without due regard to the special characteristics of a historic building. In particular, DTLR recognises that improvements to the building envelope, and especially thermal insulation, can be particularly difficult for architecturally or historically important buildings. Alterations are often impossible – at least to some elements – without unacceptable damage to the historic fabric or cultural record, or the creation of uncertain technical risks, e.g. exacerbating risks of decay in timber. Similarly, opportunities for energy saving should not be missed just because a building is of historic or architectural interest. (Research has shown that improvements in the thermal insulation of buildings can cause problems in other areas. Designed to support the latest Building Regulations for the conservation of fuel and power, the report *Thermal insulation: avoiding risks* [Stirling 2002] explains the hazards involved in meeting Requirements when thermally insulating roof, walls, windows and floors.)

1.7 The advantage of early consultation

An early dialogue between the building control and the conservation officers in the local planning authority is encouraged. This is already standard practice in some authorities which have adopted a 'development team' approach (DETR, 1998) to give a single point of advice to applicants.

2 The context of the revisions to Part L

2.1 The need to reduce greenhouse gas emissions

The Government is committed to reducing global warming by reducing the emissions of greenhouse gases. The UK has set a target of reducing emissions of the most important greenhouse gas, carbon dioxide (CO₂) by 20 per cent on 1990 UK emissions. The target year is 2010. Operational energy in buildings – burning fossil fuels to provide energy for heating, ventilation, lighting etc. – accounts for 46 per cent of the UK's CO₂ emissions. Since new construction amounts to only about 1 per cent of the stock per year, emissions from existing buildings cannot be ignored, and need to be generally reduced, if policy aims are to be met. Historic buildings constitute less than 6 per cent of the total building stock of England, and are a precious finite resource. English Heritage believes that a contribution towards national energy conservation requirements can be made from

within this heritage stock. However, special care and a flexible approach are needed so that the interests of historic buildings can be preserved.

2.2 Extending Building Regulations to existing buildings

DTLR's amendments to Approved Document Part L of the Building Regulations came into force on 1 April 2002. They seek to improve the energy performance of all buildings, including existing ones, when altered, extended or subjected to a change of use. Before this, approval was required only if the works affected structural safety, fire safety, and access for disabled people. Now *most* modifications to a building require consent, and reasonable provision needs to be made for the conservation of fuel and power.

2.3 The purpose of this Interim Guidance Note

During the consultation stage of Part L, English Heritage liaised closely with DTLR in formulating the revised regulations to safeguard the interests of historic buildings. It was agreed that English Heritage – with the support of DTLR – would prepare an *Interim Guidance Note* to assist building control bodies when assessing applications dealing with historic buildings where the Requirements for Part L need to be satisfied. This *Note* sets out the principles that need to be considered when alterations are contemplated to historic buildings. It focuses on dwellings (Approved Document Part L1), but is equally applicable to non-domestic buildings (Approved Document Part L2).

2.4 Guidance on the application of the Building Regulations to historic buildings (especially on liaison between building control and planning teams at local level)

English Heritage is collaborating on the development and production of a *Procedural Guide* (in preparation, 2002) for local authorities on the methods to be adopted when building control bodies apply the Building Regulations to historic buildings. This further guide will highlight, from local authority good practice, the circumstances in which the advice of conservation officers in planning departments should be sought and used. The guide will recommend that, to avoid problems, liaison must start at the earliest stages of the project, well in advance of the formal control processes.

2.5 Next steps

This current *Interim Guidance Note* has been prepared to coincide with the early months during which the revised regulations came

into force (the Spring of 2002). It is hoped that further research will be commissioned by English Heritage later in 2002 to provide additional technical material for a more comprehensive document. This is intended to supersede the *Interim Guidance Note* at a date to be announced in the following year. It will include:

- generic methods for improving energy efficiency in ways that help to avoid harming the important features and qualities of historic buildings
- technical information on traditional materials
- illustrated details and case studies.

3 Historic building definitions and statutory protection

3.1 Definitions used in Part L

Paragraph 2.9 of Part L1 and Paragraph 4.10 of Part L2 identify the following as historic buildings:

- listed buildings*
- buildings situated in conservation areas*
- buildings which are of local architectural or historical interest and which are referred to as a material consideration in a local authority's development plan*
- buildings of architectural and historical interest within national parks, areas of outstanding natural beauty, and world heritage sites.*

Statutory issues affecting buildings in each of these four categories are outlined below. A conservation officer should be consulted before modifications are undertaken to buildings in any of these categories. Many buildings of architectural, townscape, landscape or historic interest do not fall into any of these specific categories but also require sensitive consideration.

3.2 Listed buildings

Listed buildings are those included on the statutory List of Buildings of Special Architectural or Historic Interest. Controls apply and Listed Building Consent is required for any works of alteration or extension – both external and internal – which would affect a building's character. Fixtures and curtilage buildings – i.e. any objects or structures which are fixed to the building, or are within the curtilage (and have been so since before July 1948) – are treated as part of the listed building. The same controls apply whatever grade of listing the building is given.

The Government's policies on the

conservation of listed buildings are enshrined in PPG15 (DNH and DoE, 1994). Works which materially and detrimentally affect the special architectural or historic interest of the listed building should not receive the benefit of consent. Paragraph 3.26 advises that 'the Building Regulations should be operated in a way which avoids removal of features which contribute to the character of a listed building, and authorities should consult their own conservation officers, or seek expert advice from other sources, when handling difficult situations.'

3.3 Buildings in conservation areas

Conservation areas are 'any areas of special architectural or historic interest, the character or appearance of which it is desirable to preserve or enhance'. Conservation Area designation encourages authorities to implement conservation policies over these sensitive areas.

In a conservation area, the main emphasis is on external appearance, with surface materials (walls and roofs) and the details of windows, doors, and rooflights being extremely important. Changes to these may need planning permission, especially if they are subject to an Article 4 direction (see Box 4) under the Town and Country Planning Acts. Consent is also needed for the demolition of most buildings in a conservation area.

Consent is not needed for internal alterations to unlisted buildings. While not all buildings in a conservation area will be of historic interest, many are: original internal and external features contribute to the importance of these and therefore have a direct impact on the character of the area.

3.4 Buildings of local architectural or historic interest referred to in a local authority's development plan

This category includes a local authority's 'local list' or 'supplementary list' of historic buildings, which has been included in their unitary or local plan (known as the development plan). Inclusion within the plan means that any list of this kind has been subject to public consultation and is a material planning consideration in the determination of applications under the Town and Country Planning Acts.

Most buildings on these lists are good examples of a particular design or style of construction, e.g. buildings of the Arts and Crafts movement of the late 19th and early 20th centuries, the work of a noted local architect, or a building associated with a local historical figure. They could well become the

listed buildings of the future.

These buildings have no statutory protection unless they are within a conservation area. Nonetheless, if they are to retain their importance it is often essential that original features and fabric are preserved in any schemes of alteration or extension.

3.5 Buildings within National Parks, Areas of Outstanding Natural Beauty, and World Heritage Sites

Buildings often help to create the townscape and landscape qualities which were amongst the original reasons why an area or a site achieved its designation. They use local materials and highlight vernacular traditions. Elements such as roofs, windows, rooflights and doors typify their period, age and style. While these designated areas do provide slightly more control over 'permitted developments' than elsewhere, many important features on unlisted buildings are not safeguarded, and improvements to energy efficiency must avoid harming them. (Other buildings in these areas may be relatively modern or much altered, and may accommodate energy-saving features more easily.)

Box 4 The Town and Country Planning (General Permitted Development) Order 1995

Article 3 of this Order grants planning permission for various classes of development which are set out in schedule 2 of the Order. These are known as 'permitted development' and include, for example, replacing windows in a non-listed building.

An Article 4 direction may be made by a Local Planning Authority or by the Secretary of State where either is satisfied that it is expedient that the permitted development (with some exceptions) should not be carried out unless permission is granted for it on application. If in Article 4 direction was in place and included windows, then an application for planning permission would be needed for replacements.

3.6 Other buildings

Other buildings may fall outside any of the categories above, but have historic and architectural features for the preservation of which a sound case can be made. These include:

- buildings in historic parks and gardens
- buildings in the curtilages of Scheduled Ancient Monuments
- buildings or groups with distinguishing local or architectural characteristics which are often regarded as commonplace until

they vanish. For example, in recent years inappropriate window replacements have taken their toll on many previously harmonious and well-proportioned vernacular buildings.

If in any doubt, consult a conservation officer (or a nominated officer).

4 Principles of repair and alteration to historic buildings

4.1 The sensitivity of historic buildings

A historic building in its townscape or landscape setting, complete with its interior decoration, fixtures and fittings, can be regarded as a composite work of art and document of history. Historic buildings vary greatly in the extent to which they can accommodate change without loss of their special interest. Some are sensitive to even slight alterations, particularly externally, and where they retain important interiors, fixtures, fittings and details. Others may have changed significantly and restoration is not considered feasible or sensible. These considerations will influence the extent of change that is appropriate to improve energy efficiency.

4.2 Principles outlined in Part L

Parts L1 and L2 state: *The need to conserve the special characteristics of ... historic buildings needs to be recognised ... the aim should be to*

improve energy efficiency where and to the extent that it is practically possible, always provided that the work does not prejudice the character of the historic building, or increase the risk of long-term deterioration to the building fabric or fittings. In arriving at an appropriate balance between historic building conservation and energy conservation, it would be appropriate to take into account the advice of the local planning authority's conservation officer.

4.3 Identifying the special elements

Before considering any alteration, it is essential to assess the elements that make up the special character and interest of the building, including:

- *External features* such as a decorative façade, windows and doors
- *The spaces and internal layout* The plan of a building is one of its most important characteristics. Interior plans should be respected and left unaltered as far as possible.
- *Internal features* of interest such as decorated plaster surfaces, panelling, floors, window shutters, doors and doorcases
- *Details* such as mouldings, stucco-work, wall and ceiling decorations can be just as valuable in simple vernacular and functional buildings as in grander architecture, and can be a building's most important features.

Besides the historical or aesthetic importance of a building and its fixtures, the

archaeological or technological interest of the surviving structure and surfaces may also be significant.

4.4 Principles of minimum intervention

A traditional building needs to be considered as a whole and treated in a holistic way. Its structure, materials and methods of construction and patterns of air and moisture movement should be properly understood. A fundamental principle is to minimise intervention. The stock of historic buildings is finite and every loss or major alteration to fabric is significant. Therefore a conservative approach is needed with knowledge and experience to determine what is important and how changes can be made with the least effect on the character of the building.

4.5 Principles of repair

Where new work can be carried out with minimal effect on historic fabric, it should be carefully matched and blended with the old in order to achieve an architectural whole. As much old work as possible should be retained and recorded (Clark, 2001). New materials introduced in the course of like-for-like works should match the original materials as closely as possible. The detailing of the new work should match the original or existing work exactly.

4.6 Principles of alteration

When alterations for energy conservation are proposed, regard should be given to:



Figure 1 (a, above) Double glazing in PVCu cannot replicate the appearance of an original timber sash with fine glazing bars. (b, right) An unfortunate combination on the same façade: original timber sashes (ground floor), PVCu replacements (first floor) (Photographs: Chris Wood and English Heritage Building Conservation and Research Team)



- ensuring that the building is well understood, to avoid damage
- minimising disturbance to existing fabric
- reversing the changes easily without damaging the existing fabric (especially changes to services)
- appreciating that some buildings or parts of buildings are of such quality, importance or completeness that they should not be altered at all save in the most exceptional circumstances.

BS 7913:1998 expands on these principles.

4.7 Understanding how the building works

Many historic buildings include soft, weak or permeable materials, e.g. mortars, plasters, renders and paints. These cause the fabric to respond in fundamentally different ways to air, moisture and structural movement from the hard, strong, impervious materials and membranes widely used in modern construction. Before any work is carried out, it is therefore important that a building's system of construction and the way in which this might have changed over time is understood – and that alterations are compatible with this system.

4.8 Introducing modern materials

To use modern substitutes and to introduce impermeable materials or membranes into permeable traditional construction is usually not good practice and can lead to trouble. Obvious examples include the use of cementitious mixes for plasters, renders and pointing where, for example, incompatibilities in flexural strength, permeability and porosity can lead to disastrous salt migration and damage. As a general rule materials and techniques designed for new construction should be treated with caution and if possible avoided, as their long term or side effects on a building or its occupants are not fully understood. That said, some new synthetic or natural materials used thoughtfully and skilfully, e.g. for permeable insulation, can facilitate the most conservative and economical work.

5 Specific references to historic buildings in Part L

5.1 Introduction

As outlined above, the Part L revisions:

- appreciate that historic buildings require different approaches from modern ones
- recognise the potential conflicts between building and energy conservation and seek to mitigate them by taking a flexible approach

- allow what is reasonable to be determined in relation to each building's special characteristics.

This Section examines specific issues raised.

5.2 What triggers the Part L Requirements?

For existing buildings, Part L generally requires energy conservation upgrading only for elements which are to be 'substantially replaced' as part of the works. The Requirements do not apply to normal repair and patching work. While a 'material change of use' could trigger wider-ranging upgrades, Part L states that consideration would be on individual merits and would need to take account of historic value.

5.3 Determining the special characteristics

Advice on the factors determining the character of historic buildings is set out in PPG 15 (L1, paragraph 0.19; L2, paragraph 0.24).

To determine the special characteristics requires knowledge and experience. Advice from the conservation officer should usually be sought, not only to identify which parts of

the structure are original or of historical or architectural importance, but also the significance of layout, plan-form and spaces.

5.4 Specific guidance in Parts L1 and L2

Specific guidance is reproduced in Box 5. Paragraphs 2.9 and 2.10 have already been reviewed in Sections 3 and 4 above.

Paragraph 2.11 mentions circumstances in which it might be reasonable to reverse previous interventions, to replace features in the original manner, or to improve moisture control, even if this were to reduce energy performance. For example, it might be permissible to:

- replace inappropriate double glazing with single-glazed windows which match the originals
- relax the strict interpretation of Part L for works of reconstruction and infill where this would prejudice the creation of an appropriate facsimile
- allow the fabric to 'breathe' in spite of the extra heat loss which may occur through reduced insulation and/or higher ventilation rates. This is discussed further in Section 7 of this *Interim Guidance Note*.

Box 5 Sections 2.9 – 2.11 of Part L1

(Note: apart from some numbering, Section 4 of Part L2 is identical to the content of this box)

2.9 Historic buildings include –

- a) listed buildings,
- b) buildings situated in conservation areas,
- c) buildings which are of architectural and historical interest and which are referred to as a material consideration in a local authority's development plan,
- d) buildings of architectural and historical interest within national parks, areas of outstanding natural beauty, and world heritage sites.

2.10 The need to conserve the special characteristics of such historic buildings needs to be recognised¹. In such work, the aim should be to improve energy efficiency where and to the extent that it is practically possible, always provided that the work does not prejudice the character of the historic building, or increase the risk of long-term deterioration to the building fabric or fittings. In arriving at an appropriate balance between historic building conservation and energy conservation, it would be appropriate to take into account the advice of the local planning authority's conservation officer.

2.11 Particular issues relating to work in historic buildings that warrant sympathetic treatment and where advice from others could therefore be beneficial include –

- a) restoring the historic character of a building that had been subject to previous inappropriate alteration, e.g. replacement windows, doors and rooflights;
- b) rebuilding a former historic building (e.g. following a fire or filling in a gap site in a terrace);
- c) making provisions enabling the fabric of historic buildings to 'breathe' to control moisture and potential long term decay problems².

1 BS 7913: 1998 'Guide to the principles of the conservation of historic buildings' provides guidance on the principles that should be applied when proposing work on historic buildings.

2 Hughes, 1986 'The need for old buildings to breathe'

Figure 2 The layout, plan form and spaces are vital features of historic buildings and need to be understood before changes are proposed. (Digital image by Ray Martin from English Heritage original)



6 Meeting the Requirements of Part L

6.1 Introduction

Better energy efficiency can be achieved by physical change to the building fabric and services and/or by more mindful behaviour by occupants. Building Regulations tend to influence only the physical changes – though they can facilitate better behaviour, for example by improving controls and usability and (in the current revisions to Part L) by beginning to require better sub-metering, commissioning records and log books for heating and cooling systems, and power and lighting.

6.2 The Statutory Requirements

The Statutory Requirements for non-domestic buildings are summarised in Box 6.

Box 6 The Statutory Requirements (Source: Part L2 of the Approved Document, page 8)

- L2. Reasonable provision shall be made for the conservation of fuel and power in buildings or parts of buildings other than dwellings by
- (a) Limiting the heat losses and gains through the fabric of the building
 - (b) Limiting the heat loss
 - (i) from hot water pipes and hot air ducts used for space heating
 - (ii) from hot water vessels and hot water service pipes
 - (c) Providing space heating and hot water systems which are energy-efficient
 - (d) Limiting exposure to solar overheating
 - (e) Making provision where air conditioning and mechanical ventilation systems are installed, so that no more energy needs to be used than is reasonable in the circumstances
 - (f) Limiting the heat gains by chilled water and refrigerant vessels and pipes and air ducts that serve air conditioning systems
 - (g) Providing lighting systems which are energy-efficient
 - (h) Providing sufficient information with the relevant services so that the building can be operated and maintained in such a manner as to use no more energy than is reasonable in the circumstances

The Requirements for dwellings include items (a)–(d) and (h), which apply only to heating and hot water services for domestic buildings.

Items (e) and (f) apply to buildings with a floor area greater than 200 sq m and (g) to those with a floor area over 100 sq m.

6.3 Relevance of the Statutory Requirements to historic buildings

- (a) *Limiting the heat losses...through the fabric* caused by conduction and air infiltration is by far the most common area of conflict between building and energy conservation.
- (b) *Limiting the heat loss from...pipes and...ducts* will not normally be a problem, except where access is difficult, or the installations are of historic interest or part of the architectural character.
- (c) *Providing [energy-efficient] space heating and hot water* will occasionally cause problems where historic equipment is to be conserved or – for example – where electric systems are preferred to avoid disruption to surface finishes or fabric caused by pipework or to limit the risk of flooding. High efficiency boilers may sometimes also be unacceptable where old flues need to be kept warm and dry, or where the ‘steam’ plume from a condensing boiler could be unsightly or could put items in its path at greater risk of damp and decay.
- (d) *Occasionally the need to limit solar heat gains* may be a problem – particularly in some 20th-century buildings of architectural interest – but these will not be dealt with here.
- (e) *‘Reasonable’ standards for air conditioning and mechanical ventilation*
Air conditioning installed in historic buildings may sometimes be less efficient than in new buildings, owing to restrictions placed on appearance, access or space.
- (f) *Insulation to air ducts, chilled water and refrigerant pipes and vessels* may sometimes be restricted for appearance’s sake, or because of limited space.
- (g) *The need for efficient lighting* may sometimes conflict with a requirement for ‘authentic’ appearance: for example, creating the more traditional ‘sparkle’ of tungsten filament lighting requires less efficient light sources.
- (h) *Good record information* is just as valuable in historic as in new buildings.

6.4 The general approach

The following broad principles should be observed when energy efficiency is being improved in a historic building:

- do not undertake unnecessary changes
- do not cause the physical or visual loss of important features
- avoid changes increasing the risk of damage elsewhere in the structure (advice may well be required from technical specialists and the conservation officer).

A holistic evaluation should be undertaken of the building’s energy efficiency. For example, while one element such as a single-glazed window may not be easily improved (except by concealed draughtproofing), another such as a thatched roof or a thick masonry wall may be capable of exceeding the recommended U-value.

6.5 Applying Part L to existing buildings

For existing buildings, there is no Requirement in Part L to upgrade elements which do not need replacing.

The purpose of Part L is not to force unnecessary intervention, but to make sure that when replacements and major alterations are undertaken, the elements are upgraded to an extent that is reasonable; and where practicable to the required standards for a new building.

When deciding whether to repair or replace, it is essential to consider the implications of destroying existing fabric against the potential benefits. For example, it would be neither sustainable nor cost-effective to replace a 200-year-old window that is capable of repair and upgrading with a double-glazed alternative, and even less so if the new window were to have an anticipated life of only 20–30 years, as some do. However – depending on circumstances – a good case might be made for well-designed and carefully-installed draughtproofing or secondary glazing (see Figure 16).

Where proposed alterations or replacements could trigger the Part L Requirement to upgrade the existing fabric, care must be exercised in deciding whether or not such work will affect the building’s character: of course, if the building is listed, Listed Building Consent may also be required. In some instances, a historic building may be in an almost totally original state, and like-for-like replacement will be the only appropriate solution. In many cases, however, *some* thermal upgrading will be practicable. For example, though wall insulation will often be inappropriate (see Section 10), it may be feasible to add insulation in roofs and under suspended floors. Provided this does not introduce technical risks (see Section 7), it might even be reasonable for this insulation to exceed the recommendations in Part L to help make up for shortcomings elsewhere.

6.6 Ventilation, airtightness and moisture control

When work is carried out to windows or insulation, the Approved Document for

Part L recommends *‘reasonable sealing measures to ensure airtightness’*. This tends to be part of a ‘build tight, ventilate right’ strategy, with ventilation rates recommended for modern buildings in Part F of the Building Regulations (DETR, 2000). However, this guidance is based primarily on dispersing moisture and pollutants generated by the occupants in modern buildings, which effectively create a barrier to external moisture. Buildings with solid walls, permeable materials and no damp-proof courses operate differently and may require more ventilation to ensure their welfare, and the comfort of their occupants, as discussed in Section 7.

6.7 Applying Part L to extensions to historic buildings

An extension will normally be able to accommodate a higher standard of thermal performance than the host building. An exception would be where the extension was designed to be a true facsimile of a previous structure or where certain planning requirements generated the need for elements to complement the historic building in terms of construction and detailing.

Sometimes an extension, such as a conservatory, can improve the thermal performance of the whole building, for example by reducing heat loss through the surface to which it is attached and enhancing solar gain. However, care needs to be taken in the design and integration of such structures:

- If unheated and isolated (for example, by doors which are usually kept closed in winter), a conservatory will normally be warmer than outside and reduce heat losses from the building to which it is attached.
- However, if heated – or unheated but left open to the adjacent building – the whole building’s heating requirements could be significantly increased.

7 Historic buildings as environmental systems

7.1 Introduction

This Section deals with issues that need to be considered in developing and reviewing an integrated approach to a historic building.

- *At the large scale*, the performance of the whole building must be assessed in a holistic approach to heating, ventilation, insulation and energy efficiency.
- *At the medium scale*, it is necessary to review how the conditions vary from place to place around the building.

- *At the smaller scale*, it can be difficult and sometimes impossible to make satisfactory junctions between different elements and construction details with different types and levels of insulation, so these must be carefully examined.

If not properly integrated at all the scales, problems can arise – in particular condensation, mould and decay.

7.2 Technical risks identified in Part L

Part L recognises that technical risks can arise in the application of energy conservation measures such as the increase of unwanted moisture and harmful effects on health. Section 0 of Parts L1 and L2 refers specifically to the following publications for guidance:

- *Thermal Insulation: Avoiding Risks* (BRE Report No 262: see Stirling 2002). This discusses many potential problems, and confirms that thermal insulation, heating and ventilation must be considered together.
- *Approved Documents parts F, J and E* on ventilation, combustion systems and acoustics. (Only the ventilation aspects are covered in this *Interim Guidance Note*.)
- *Robust Details* (see DEFRA and DTLR, 2001) This publication refers to modern domestic construction and therefore is not directly relevant to historic buildings. However, it illustrates the technical implications of applying the principles outlined in Part L and by Stirling (2002) and so may assist review and discussion of their relevance to conditions encountered in a historic building.

7.3 Risks associated with thermal upgrading

Thermal Insulation: Avoiding Risks (Stirling 2002) goes over many of the problems that can arise in new buildings or major alterations. However, three general requirements in its first section often prove difficult or impossible to satisfy in historic buildings:

- ***Insulating the structure uniformly, avoiding thermal bridging*** Problems often arise at the junctions between different elements and construction details. Ensuring continuity is often difficult, as discussed below.
- ***Providing a well-controlled heating system, with heat emitters in rooms where heat will not be gained from heated spaces elsewhere*** This is to help reduce moisture levels and avoid condensation. However, in many historic buildings there are unheated rooms, void structural gaps and other spaces in which

condensation risks could increase if other parts of the building were upgraded and/or air infiltration rates were reduced too far.

- ***Preventing the distribution of moisture-laden air throughout the building, particularly to unheated spaces, by passive or mechanical ventilation close to the source*** In some historic buildings – or at least in parts of them – it may be impossible to install such systems without damaging their character. In addition, and as discussed below, an important source of moisture is frequently the building itself.

In developing the design of a new building or a major refurbishment, the balance between heating, ventilation and insulation can be adjusted until desired results are achieved, i.e. minimising risks whilst meeting Part L's quantified Requirements. The text of the third edition of Stirling (2002) identifies (with an 'R' in a green box) issues affecting buildings which are being renovated, altered or converted. However, these relate to strategies which aim to make the details work technically. In a historic building, the additional physical and visual constraints outlined in Sections 3 and 4 of this *Interim Guidance Note* may make it impossible to apply some of the remedies advocated.

Even if a historic building's features were completely set aside as constraints, the strict application of Part L would often not be appropriate technically. For example, given the construction and environmental behaviour of some historic buildings, the least risky solution could well require *less* insulation and *more* heating and/or ventilation than Part L envisages. This is another reason why, for historic buildings, DTLR decided that Part L should allow discretion to be exercised in determining what is reasonable.

7.4 Most historic buildings need to 'breathe'

Most historic buildings are made of porous materials and do not incorporate the barriers to external moisture (cavities, rainscreens, damp-proof courses, vapour barriers and membranes) which are taken for granted in the majority of modern construction. As a result:

Box 7 The main risks to historic buildings

In brief, these are

- trapped moisture within the construction
- condensation within the construction or in unheated areas
- condensation at thermal bridges (especially at corners)
- insufficient ventilation and heating to remove moisture

- historic structures tend to be wetter as there is often some rising and penetrating damp
- porous, breathable construction allows moisture to evaporate internally
- more ventilation is needed to remove transpired moisture
- in addition, better heating may cause internal moisture levels and dewpoints to rise, because of faster evaporation from permanently damp fabric. This can be a particular problem in intermittently-heated damp buildings, which self-humidify as they warm up.

Changes to the fabric of a building in order to reduce heat loss can alter its moisture transfer mechanisms, including the ability of the fabric to 'breathe'. Three important aspects of moisture transfer contribute to maintaining the balanced environment found in many historic buildings:

- **permeability** the capacity to allow water vapour to pass through
- **capillarity** the ability to mop up or wick away water as liquid
- **hygroscopicity** the tendency actively to draw moisture from air and store it

A modern approach to the moisture problems outlined above would be to insert air gaps and moisture barriers. Where insulation is added, particularly internally, vapour control is also essential in most modern constructions to avoid interstitial condensation. However, in a historic building, moisture movement through the structure (transpiration) can be important to the soundness of the building, e.g. cob earth-walled housing in Devon. Impervious materials intended to stop indoor moisture passing through the fabric of a modern building instead stop structural moisture getting out. Even in some modern constructions 'summer condensation' can occur on the outside of a vapour control layer (see Stirling 2002, section 3.10).

Therefore proposals to add insulation to historic buildings need to be carefully considered, for example:

- Is it desirable to add insulation, or will this increase risks and hide problems?
- How much insulation should there be (too much might lead to interstitial condensation)?
- What properties should the insulation have? (It may need to be moisture resistant, and to have a controlled amount of breathability to allow water vapour to pass through while at the same time avoiding interstitial condensation.)

These points are developed in the following sections, particularly Section 10 (*Walls*). It is interesting that in recent years both the ecological building movement and technical

developments have begun to rediscover the practicalities of breathing construction, although some aspects of the theory and of the performance of traditional buildings are not yet fully characterised.

Box 8 Controlling moisture levels

Successful control of moisture levels in a historic building often depends on:

- plentiful sources of ventilation
- permeable building materials that are hygroscopic and hence buffer moisture
- the absence of barriers to moisture flow.

7.5 Ventilation Requirements

Owing to the factors discussed above, historic buildings usually need more ventilation than modern ones. In the past, they were often more ventilated than strictly necessary because of loose-fitting doors, windows and other openings. In addition, open fires created generous rates of exhaust ventilation through chimneys at times when condensation risk might otherwise have been high.

However, if ventilation of a historic building is reduced too much, condensation, mould and fungal growth may occur, leading to deterioration of the fabric and contents, and possibly health problems for occupants. Great care is therefore required in selecting an appropriate ventilation rate for a historic building. A rule of thumb used by some designers is 'twice as much as required', though the actual amount needed varies with context, and particularly with the amount of evaporation occurring from the fabric.

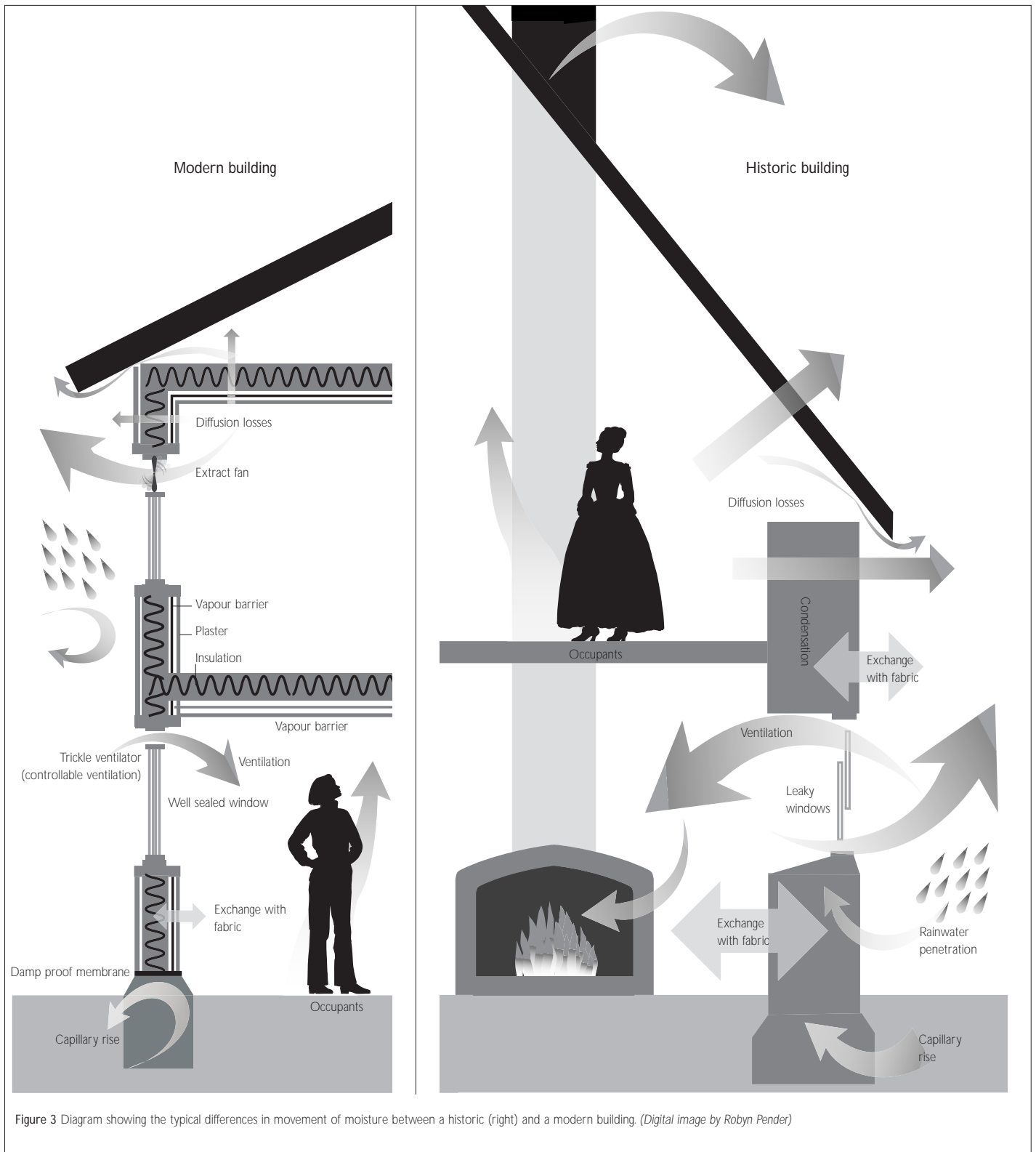

Figure 3 Diagram showing the typical differences in movement of moisture between a historic (right) and a modern building. (Digital image by Robyn Pender)

7.6 Thermal bridging

If the thermal performance of one element is improved by adding insulation while an adjacent area is not insulated, a local cold spot – known as a thermal or cold bridge – is created. For example:

- it may be possible to place insulation over a ceiling but not at the head of the adjacent wall at the eaves, which will remain cold
- alternatively, a wall may be internally lined but not the window reveal – so here the exposed edge of the newly-insulated wall actually becomes colder, and at greater risk of condensation.

If such weak spots cannot be successfully detailed (see Stirling 2002 for modern examples), then added insulation may not be desirable, or the amount of heating and ventilation may need to be increased to help avoid mould growth or condensation.



Figure 4 Enlarging the window openings and setting the frames flush with the façade (left) totally distorts the proportion and detailing of the original windows (right). (Photograph courtesy of Kit Wedd)



Figure 5 Historic glass, especially Crown glass, is rare and cannot be reproduced today. Where examples such as the middle right pane survive, they must be preserved. (Photograph courtesy of Treve Rosoman)

8 Windows

8.1 The importance of windows

Window openings and frames establish the character of a building's elevation. They should not generally be altered in their proportions or details, as they are conspicuous elements of the design. The depth to which window frames are recessed within a wall is a varying historical feature of importance and greatly affects the character of a building: this too should be respected.

The importance of conserving traditional fenestration and its detailing cannot be stressed enough, being particularly emphasised in PPG 15 Annex C (DNH and DoE, 1994). The Secretary of State has dismissed over 90 per cent of appeals against the refusal of Listed Building Consent for replacing traditional single glazed sash windows with double glazed PVCu windows because the replacements proposed would detrimentally affect the special character and appearance of the building. The fundamental objections, amongst many, are that double glazed sealed units fatten the dimensions of glazing bars inappropriately, or result in extremely poor facsimiles stuck to the face of the glass.

Old glass is of interest and is becoming increasingly rare. It is of value not just for its age, but because it has more richness and sparkle than today's flat sheets with their uniform reflections. Where it survives, it must be retained and alternative means of thermal improvement considered.



Four photographs at right: see fig 6 caption

Many historic windows, frames and glazing, have fallen victim to inappropriate replacements, but over the past decade, there has developed a greater appreciation of their value. However, many windows are still threatened and Part L must not become the agent for their thoughtless destruction. While listed buildings enjoy some protection, unlisted buildings are at high risk – even where they are in Conservation Areas, National Parks, Areas of Outstanding Natural Beauty and World Heritage Sites.

8.2 Window types and materials

The UK has a rich tradition of different window designs and materials from various periods of history. Most historic windows are timber-framed. Oak joinery (either fixed or in casements) predominated until the late 17th century, when, with the advent of the sash window, softwood was imported from Scandinavia and the Baltic States. This slow-grown, high-quality, naturally durable timber

continued to be widely used until the early 20th century, when inferior species started to be used which needed chemical preservatives to provide some degree of longevity. Historic timber is therefore not a renewable resource: it is very difficult to source timber of this quality and durability today. Where possible windows should be repaired and continue to be used.

Iron frames had been used in medieval times, and by the 16th century metal-framed glass windows were beginning to appear in secular homes. By the middle of the 18th century metal sash windows were being cast and even copper was being set in wooden frames, usually oak. All-metal window frames, both sash and casements, were introduced in the Regency period in housing and industrial and institutional buildings. Mass production in the early 20th century allowed hot-rolled steel to be used for, among others, the famous Crittall windows which were strong,

slim and non-combustible. All these windows are important historically and should be conserved.

8.3 Ventilating and draughtproofing

Most modern windows accommodate trickle ventilators for controllable background ventilation, to meet the Requirements of Part F of the Building Regulations (DETR, 2000). Older buildings often have considerable air infiltration through floors, airbricks, etc and may well not need more. Indeed, air infiltration through old windows is often excessive, so draughtproofing and weather stripping can be very effective in reducing not just heating bills by limiting the number of air changes per hour, but also reducing levels of noise and dust too. However, care should be taken to provide adequate ventilation to remove internally generated moisture and pollutants, together with additional moisture from sources such as rising damp (see Section 6.6).

Figure 6 Examples of the wide variety of timber [left] and metal windows [below] found on historic buildings. In (e) the upper part of the frame is metal, the lower part timber. In (f) the thin steel frames of the windows by Crittall are important to the design of this Grade II* Modern Movement building (Connell Ward Lucas, 1932). [Photographs (a), (c) and (d): English Heritage Building Conservation and Research Team; (f) and (i), Chris Wood; (e), (g), and (h) courtesy of Jill Channer, copyright © Jill Channer]

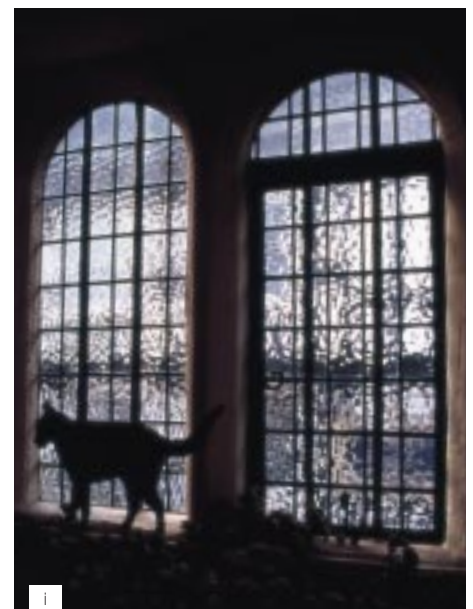

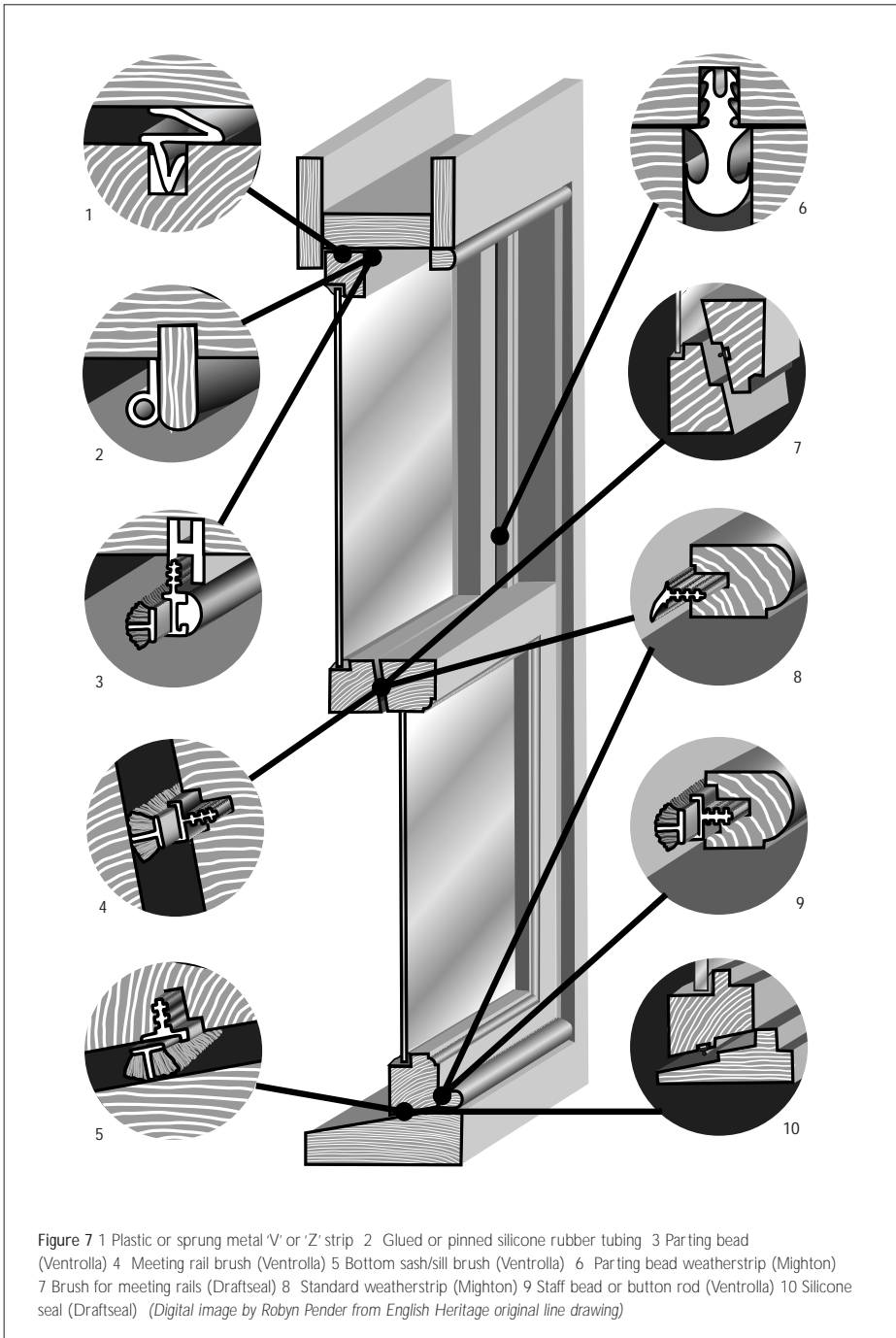

Figure 8 Draughtproofing strip being inserted into a routed channel on the bottom rail of the top sash. (Photograph courtesy of Ventrolla Ltd)



Figure 9 Secondary glazing can provide very effective thermal improvement. In historic buildings its successful insertion depends on fitting within the reveal in such a way as not to damage historic fabric. However, secondary glazing can sometimes produce an unsatisfactory reflection when viewed from the outside. (Photograph courtesy of Kit Wedd)

Several forms of draughtproofing are available, which operate in different ways:

- Some types simply act as gap fillers, and are applied as mastic or foam.
- Other forms keep out the weather by means of a snug, slightly oversized fitting, comprising silicone rubber tubes, polypropylene and nylon-filled pile brushes, or with rubber, polyester, or sprung-metal 'Z' and 'V' fins.

For steel and timber casements, a self-curing silicone rubber sealant can be injected into the gap between the window and the frame. The window is first cleaned, and overhauled so that hinges and catches operate easily. The opening edge of the casement is temporarily coated with a non-stick gel. The silicone is then injected and sticks to the non-treated frame, but not to the coated casement edge.

Box 9 Silicone sealants: a warning note

Care should be taken in selecting silicone sealants, as some (but not by any means all) mastics produce *acetic acid* which can damage painted surfaces and corrode metalwork. The safer alternatives produce *alcohol* which simply evaporates. Always be aware and read manufacturers' labels.

A good draughtstrip should insulate, be durable and inconspicuous. A number of firms now provide an effective specialist installation and refurbishment service for existing windows. According to one leading company, these products reduce the number of air changes from between 2.5 and 3.0 to 0.7 per hour. In terms of reducing heat loss, draughtproofing a single-glazed window has roughly the same effect as fitting an additional sheet of glass.

8.4 Improving window insulation

No historic window can reach the U-values recommended in Part L (i.e. 2.0 – 2.2 W/m² deg C: see **Glossary**). So-called 'facsimile' replacements have been developed with double-glazed sealed units and low emissivity glass, but in most cases these fail to provide an adequate visual alternative owing to the frame thickness required to accommodate the glazing cavity. It is impossible to replicate original glazing bars in double glazing. Except where replacement is inevitable, the aim should usually be to improve thermal performance whilst retaining the existing windows.

Recommended methods of improvement are discussed in English Heritage's *Framing Opinions Campaign* publications (English Heritage, 1994). These include:

- Draughtproofing, as described in 8.3. This is the most cost-effective and least intrusive method.

Figure 10 Shutters are not just historically important, they can provide significant thermal improvements as well as enhanced security and reduction of dust and noise. (Photograph: (b) courtesy of Matthew Slocombe and the Society for the Protection of Ancient Buildings; (a), (c), (d) and (e) by Chris Wood and other members of English Heritage Building Conservation and Research Team)



- Secondary glazing improves insulation, draughtproofing and noise control. If carefully designed, it can be relatively unobtrusive, e.g. with divisions in the glazed panels hidden behind meeting rails or glazing bars. However, not all windows are suitable for secondary glazing, owing to the narrowness of the internal sill or reveals; the difficulty of accommodating the

new panes within an oddly-shaped or unduly protruding architrave; or clashes with internal shutters.

- Old louvered and panelled external shutters are important features and often contribute to the design of an elevation. Repairing and using close-boarded and panelled external and internal shutters can minimise heat loss at night and when rooms are unused, and

also reduce unwanted solar gains. Internal shutters can also be draughtproofed to improve thermal performance, in a similar manner to windows.

Traditional means of minimising heat loss are still effective, such as heavy lined curtains. Modern alternatives include insulated curtains and reflective and/or insulated internal blinds.

Single-glazed	Double-glazed 12 mm gap	Double-glazed Low ε	Secondary glazing	Single-glazed + curtains	Single-glazed + night shutters
					
U ~ 4.8	U ~ 2.8	U ~ 2.0	U ~ 2.9-3.4	U ~ 3.6 *	U ~ 3.0 *

Figure 11 Indicative U-values applied to vertical glazing, assuming wooden or PVCu frames. (The values shown are in $W/m^2 \text{ deg C}$: see Glossary.) Estimates for single-glazed windows (without draughtproofing) with shutters or closely-fitting lined curtains with pelmets apply when they are closed. Thermally insulated curtains would improve the effectiveness even more. It is hoped that the results of detailed testing of these will be published in a more comprehensive document: see 2.5. (Digital image by Robyn Pender)

8.5 Rooflights

Most old rooflights are single-glazed, set in cast iron or timber frames, or sometimes with unframed sheets of glass replacing slates or plain tiles. Frames are often ill-fitting, and draughtproofing may improve this. Where replacement is essential, double-glazed copies of original rooflights are available which can be acceptable in historic buildings.

9 Doors

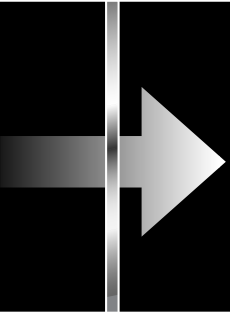
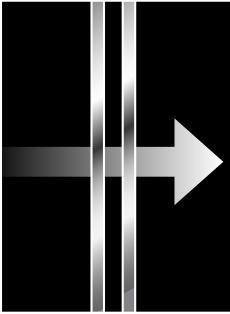
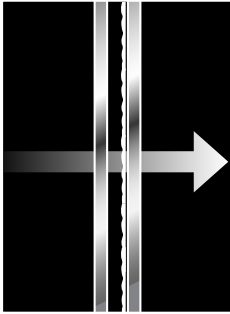
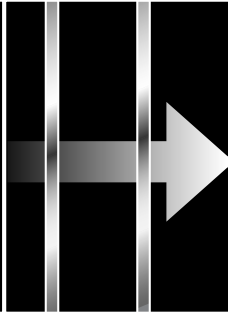
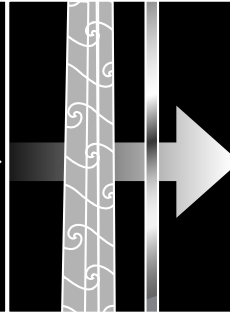
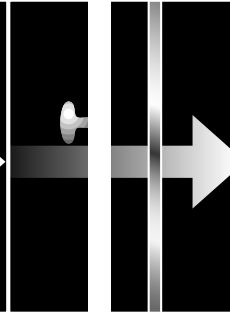
9.1 Typical construction

Most external doors on historic buildings were made of timber, many in hardwood frames. Depending on their age and design they were usually morticed and tenoned together, either in a flat plane, or with panels fitted between stiles, and muntins and rails. Doors which are original or of historical interest must be kept.

9.2 Thermal properties

Solid doors often have reasonable insulating properties. Most of the heat loss usually occurs by infiltration around the perimeter of the door or where gaps have developed around panels, at the junction with the door closer, through locks, etc. Repairs and draughtproofing may be helpful. Where space in the plan form and architecture permit, an internal draught lobby with a well-fitting (and if necessary well-insulated) inner door may be a practical solution.

9.3 Glazed doors

If a door – including the frame – has more than 50 per cent of its internal face glazed, Part L treats it as a window (see Section 8

above). Existing glazed doors should be retained, and all original or historically important glass kept. It will often be easiest to improve thermal performance with thick insulated curtains or a draught lobby, if these can be fitted without detriment to other historic or architectural features.

10 Walls

10.1 External appearance

Historic buildings display a wide range of materials and forms of construction, ranging from stone or earth walls perhaps two metres thick, to timber-framed buildings with comparatively thin and lightweight wattle-and-daub infill panels. The appearance of the external walls is usually one of the most important aspects of a historic building, while the materials give the building its unique and often local character. Other than repairs or repointing, they are unlikely to tolerate much change without exacerbating decay problems and detrimentally affecting their special interest and appearance.

10.2 The use of porous materials in walls

Most historic buildings in the UK have solid walls in porous materials, with internal finishes such as lime plaster, which is itself porous. This porosity has helped to keep many buildings in good condition.

- On the outside, it acts as a thick overcoat, absorbing rainwater, and allowing it to run down, drain out and later to evaporate.
- On the inside, it helps to stabilise moisture levels in rooms and often averts surface condensation, for example in crowded conditions or when cooking.
- Moisture can also pass through the wall and evaporate both externally and internally as conditions allow, as can any dampness rising from the earth.

This approach differs greatly from most modern buildings, which rely on:

- impervious or rainscreen systems externally

- internal construction which is completely protected from moisture – at least in theory – by cavities, damp-proof membranes, and vapour control layers.

10.3 The importance of transpiration

Where walls need to transpire moisture and vapour effectively, new materials – which were intended to form barriers to unwanted moisture or water vapour – can impede the very processes which helped a historic wall to endure. Examples are commonplace, including:

- hard cement mortar pointing which catches rainwater and diverts it into a wall, by-passing the overcoat effect
- hard external rendering, intended to keep the rain out, which also stops moisture evaporating and causes the wall to become damper. When cracked, it also traps rainwater, making things even worse.
- modern impervious paints which cause previously sound plaster to break down, because rising and penetrating damp can no longer evaporate
- other impervious materials applied internally which cause moisture to accumulate. This in turn leads to decay of embedded materials (such as timber) which are hidden from sight until deterioration has become severe. The impervious layers can lead to a build-up of salts in the underlying substrate. The salts then crystallise and rupture the original construction.

Many insulation products lose their insulating qualities when wet, so moisture from damp walls or interstitial condensation can make them useless. Other products, including some natural materials, are less affected. However, care must be taken in selecting appropriate materials that do not result in new problems such as insect infestation.

10.4 Improving insulation externally

The opportunity to improve the thermal performance of walls externally will often be limited in a historic building because of the

impact external insulation has on the appearance of the building: notably on its proportions, and on details such as quoins, window reveals, cills, thresholds etc – all unacceptable in terms of planning and Listed Building Consent (see Section 10.1).

However, there may be opportunities to insulate externally, for example where tile hanging or weatherboarding has to be removed and replaced; or where a wall suffering from chronic driving rain problems has to be re-clad. Another possible exception is where rendering requires complete replacement. However:

- Modern external insulation and rendering systems, though technically possible, may not be appropriate owing to the dimensional differences.
- Whilst a render which is thermally more effective might be used, the main criterion is that repairs should be carried out on a like-for-like basis, which means adhering to the original mix of materials. This is also important where transpiration is required (see Section 10.3).

10.5 Improving insulation internally

In historical terms it is important to ensure that internal walls are always investigated with care in advance of any changes, in case ancient or interesting features – such as early plaster and paint schemes – are hidden in the plaster or behind panelling or other coverings. Timber panelling, plaster mouldings or enriched decorations are all-important and need to be preserved.

Where complete internal re-plastering is required – particularly where it has been done before and when little or nothing of historic interest survives – there may be opportunities to incorporate internal insulation. However:

- The dimensional changes may be unacceptable at window and door openings and where original surface details such as dados, cornices, etc survive.
- The loss of space may also be unacceptable.
- Moisture may be trapped and interstitial condensation may occur.
- Insulation covers up the mass of internal walls, reducing their effect in stabilising the indoor temperature and humidity levels.
- Thermal bridges may occur at edges and junctions, e.g. between floors and internal walls.

11 Floors

11.1 Flooring generally

The appearance of a floor can be a highly distinctive feature of a historic building. Generally floors should not be lifted because

of the damage that is inevitably caused: a worn, uneven appearance is also often valued and cannot be completely re-created. However, if floors have to be lifted or replaced, there are opportunities to improve insulation.

11.2 Solid floors

Solid floors, such as those laid with stone, brick, early concrete, plaster or lime ash, cannot be insulated without first excavating them. Generally this should be avoided, unless it is the only way to remedy some destructive defect. In reconstruction, damp-proof membranes will usually be incorporated both as normal practice and to protect the insulation. However, membranes can cause more problems by driving moisture up walls and columns.

11.3 Suspended floors

Floorboards can often be lifted and insulation installed with comparative ease (Hughes 1988). However, care should be taken if:

- the floorboards have a structural function, i.e. acting as a plate membrane in early 18th-century construction: houses have been known to collapse when all the floorboards on one level were removed at once
- early wide hardwood boards (usually oak or elm) are used, particularly if these have been undisturbed and cannot be lifted without causing damage to the boards or joists
- there are historic examples of sound-deadening or fireproofing between joists: these should be preserved.

Some methods used with modern suspended timber floors are outlined in Stirling 2002, Section 5.15, and will sometimes suit historic buildings too.

11.4 Underfloor ventilation

Suspended timber floors are – or should be – ventilated underneath. This is usually intended to be cross-ventilation between underfloor openings or air bricks on opposite sides of the building. However, in practice, air often comes in through external openings and then passes between the floorboards before rising up within the building or into flues. Adding insulation (or floor coverings) can reduce this airflow and increase moisture levels both under the floor and in the building. The adequacy of underfloor and building ventilation should therefore be checked. Some information on modern construction (in Stirling 2002, Section 5.17) is also relevant.

12 Roofs

12.1 External appearance

The roof of a historic building is often its most striking feature. Most have survived in remarkably unchanged condition for many centuries. With stone, slate or tile, re-covering tends to become necessary when the fixings fail; and much of the covering material is often re-used on the same building or elsewhere. With thatch, shingles, lead and other metals, failure is more often attributable to the natural life of the covering itself.

12.2 Roof structure

Unless there has been substantial water leakage, the roof structure will usually be in good condition. Often this is attributable to the generous amount of ventilation in historic buildings and in their roofspaces. Even though a historic building may generate a lot of moisture internally – some of which finds its way into the roof – it is quickly removed. The moisture-buffering effect of the large amounts of hygroscopic material in many historic buildings can also be helpful.

12.3 Improving thermal performance

Proposals to improve the thermal performance of the roofspace have to be considered in relation to the use and performance of the rest of the building. For example:

- modern living tends to introduce more moisture into buildings and roofspaces
- ventilation rates are often reduced, exacerbating the problem
- the air and vapour control layers (AVCLs) often used in modern construction are virtually impossible to install in existing ceilings with any degree of effectiveness
- added insulation tends to cause roofspace temperatures to drop, adding to potential moisture problems.

Issues and solutions tend to vary with the type of roof: pitched or flat, with or without ventilated roofspaces. These are outlined in the following paragraphs.

12.4 Pitched roofs with ventilated roofspaces

For traditional roofs with ‘cold’ roofspaces ventilated by outside air, it will often be possible to lay insulation over the ceilings or between floor joists in the conventional manner. The use of semi-rigid batts will guarantee a minimum thickness, but a wide range of other materials is also available.

Air infiltration from the building into the roofspace should be reduced, in particular by closing up holes around pipe, duct and cable routes, especially from high humidity areas.

Even where holes are well sealed, air and water vapour from the building will still get in. In winter, the extra insulation makes the roofspace colder than before, so the risk of dampness and condensation may increase, particularly if ventilation is limited or poorly distributed.

Sometimes additional roofspace ventilation may have to be introduced. However, research has shown that not all roofs in historic buildings – particularly low-pitched ones – benefit from this. Beneficial effect is lacking when the extra ventilation serves merely to lower the temperature while not sufficiently diluting the moisture which escapes into the roofspace from the building below. In such circumstances it is essential to understand what is happening to the internal environment here, in order to determine the likely effect of insulation and ventilation on the existing fabric; and not to introduce additional ventilation gratuitously.

12.5 Pitched roofs with insulation at rafter level

Where there are rooms in the roof, Stirling (2002) recommends a 50 mm ventilation path beneath the roof finish, insulation, a vapour control layer, boxing to contain service runs without perforating the vapour control layer, and an internal lining. It is important to maintain the through flow of air when detailing new dormers or rooflights. Few historic buildings would meet these requirements.

When upgrading utilitarian attic spaces, however, it may be sometimes be possible to adopt these modern details. Alternatively, improved insulation can still be provided and the extremes of driven rain or snow combated by traditional means. Such applications maximise the permeability of the structure effectively absorbing most of the increased moisture in the short term, and allowing it to disperse slowly (Figure 12).

12.6 Flat and low-pitched roofs

Most historic flat roofs are covered with lead, a few being clad in zinc or copper. Repairs and replacements using bitumastic materials and felts have been widely used. Flat roofs show a wide variety of designs, although most are akin to the ‘cold roof’ with a small roofspace (sometimes deliberately ventilated to the outside, but often not) above the ceiling. Some roof-decks in fact form the ceiling, though this is mostly confined to churches.



Figure 12 An attic being converted for use as a habitable room where the requirement was not to strip the stone slates. Traditional torching prevents ingress of driven rain, and protection and thermal improvement is provided by: torching, a lightweight permeable building paper to underside of rafters, natural wool insulation, cellulose/jute batts, wood fibre boards and a lightweight mineral wool insulation board (or reed board) coated with lime plaster and subsequently limewashed. (Photographs courtesy of Richard Oxley, Oxley Conservation, © Richard Oxley)

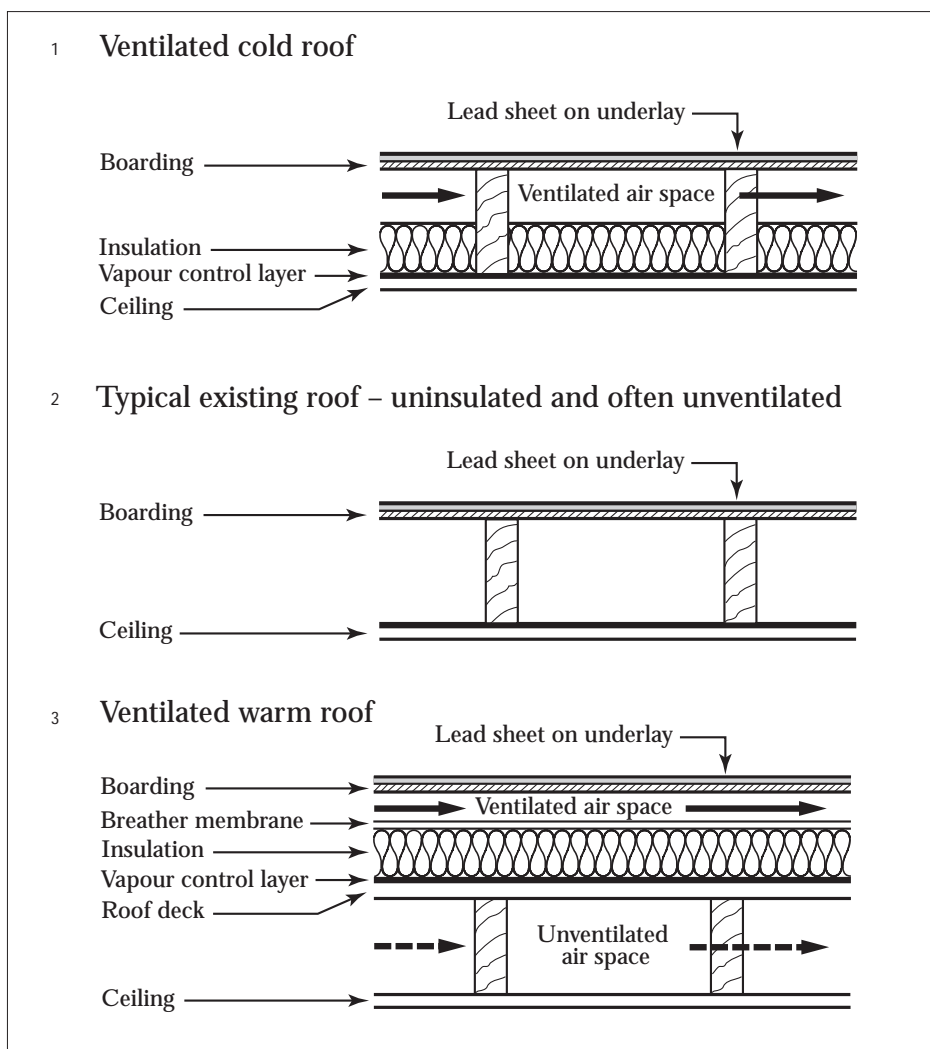

Figure 13 Examples of flat roof covered with lead: 1 Insulation of typical cold roof 2 Research has shown that despite lack of insulation and ventilation this form of roof structure has performed well. 3 Recommended modern practice which is acceptable on historic buildings provided that historic detailing is not adversely affected by the raised roof structure. (Digital images by Ray Martin, adapted with kind permission from the Lead Sheet Association for reference to the Association's original drawings)

12.7 Flat roofs with ventilated cold decks

These have always been problematic technically. According to Stirling (2002) they are a poor option in the temperate, humid climate of the UK and usually it is not possible to upgrade their thermal insulation. If there is no alternative to cold deck designs, Stirling recommends providing a continuous vapour control layer above ceiling level, lapped and taped throughout, and also sealed to the walls at the edges. Service penetrations should be avoided unless this is impossible, in which case they should be carefully detailed and effectively sealed. Cross-ventilation should be generous, without any blockages, and with open eaves at each end: cold roofs should not be used if the structure spans between parapet or abutment walls.

In spite of the above, research has shown that even with little roofspace ventilation and no air and vapour control layers at ceiling level, lead roofs have often survived well by virtue of the balanced environment which has been created. The summer heat dries the timbers and other porous materials in the roofspace. In winter, moisture from below is absorbed or buffered by the timber which then dries out thoroughly again in summer. In effect this mechanism has allowed some metal roofs and timber structures to survive for centuries. Adding ventilation and insulation to this type of construction – or increasing moisture levels within the building – can change these conditions for the worse. Moisture problems affect not only the timber substrates and roof structure, but can also shorten the life of metal roof coverings by inducing corrosion on the underside.

12.8 Flat roofs with warm decks

To upgrade the insulation of a 'cold' flat roof, Stirling (2002) states that the preferred option is to convert it to a sandwich or inverted warm deck roof. However, while sandwich construction can work for felt and asphalt roofs, installations in the 1970s and 1980s showed that a continuously-supported metal sandwich roof could draw external moisture into the sandwich itself and suffer from decay and corrosion. Lead roofs on historic buildings were particularly susceptible, as described in English Heritage's *Advisory Note* on the subject (English Heritage and LSA, 1997) and warm roofs are not recommended.

12.9 Ventilated warm roofs

Modern practice for metal-clad roofs is set out in the three volumes of the Lead Sheet Association's *Manual* (LSA, 1990, 1992, 1993), which advocate the use of ventilated

warm roofs. The principle here is the creation of a new insulated and ventilated roof deck structure, completely isolated from below. If this is correctly detailed and carefully constructed it is an effective design, but great care is required with continuity of ventilation and of vapour control, as discussed in *Lead roofs on historic buildings* (English Heritage and LSA 1997). However, on some historic buildings, notably those where the roofs are prominent or the abutment detailing or appearance is important, e.g. under a clerestory window cill or low parapet, it is not acceptable to raise the roof by the requisite height – often about 250 mm. There may also be structural problems. In these cases, the opportunity to improve insulation may be limited, and it is important to heed the warning about the gratuitous introduction of additional ventilation.

12.10 Materials and details

Thermal bridges can occur at gaps in the insulation and at junctions with chimneys and outside walls. Care will be needed to ensure that these do not introduce condensation problems, as discussed in Section 7 of this *Interim Guidance Note* and Stirling 2002, Section 2.

Sarkings Tile, stone and slate roofs used to be laid without sarking felts, although sarking boards were occasionally used. Re-roofing today almost invariably includes underfelts, to allow re-roofing to take place in bad weather; and to provide secondary protection against wind-driven snow and rain. Vapour-permeable materials are preferred: as a general rule, the more vapour-permeable the better. However, even they reduce air movement, and alternative provision for ventilation may be necessary, though designed 'breathing' construction is now becoming possible. Additional ridge ventilation can be unsightly.

Insulating foam Isocyanurate is sometimes sprayed directly onto the underside of slates and tiles, and sets into a hard layer with strong adhesive properties. Foams are claimed to improve insulation and waterproofing, prevent tiles or slates slipping, and avoid condensation. **Sprayed insulating foams on slates and tiles are NOT recommended for historic buildings:** they prevent the slates and tiles being salvaged during the next re-roofing, the tiling battens and the upper parts of the rafters are sealed in, which may lead to rotting and premature degradation, and the normal flow of air into the roofspace is restricted.

Thatch provides one of the best natural insulators and should not need further insulation. A 300 mm thatched roof made of water reed (thermal conductivity 0.09 W/m deg C) or straw (thermal conductivity 0.07 W/m deg C) will have a U-value of 0.3 W/m² deg C and 0.23 W/m² deg C respectively.

13 Building services

13.1 Introduction

Sometimes the building services in a historic structure will themselves be of historic interest. If so, advice will need to be sought from the Conservation Officer on whether they should:

- remain in use unaltered
- be refurbished and re-used
- be left for visual effect or for historic reasons but be functionally replaced
- be taken carefully into storage.

Apart from these considerations, the energy efficiency of building services in a historic building should cause few problems, provided that care is taken. Much advice is available in CIBSE Guide F (1998), and in the publications of the Energy Efficiency Best Practice programme.

More relevant detailed advice on strategies, equipment and installation is expected to be included in *Energy efficient building services and fabric for historic building: a good practice guide for historic and traditional buildings* (CIBSE, in preparation). Only brief notes are therefore included below.

As a matter of good practice, but particularly where improvements to the fabric are impossible, it is important to consider improving the services to a level beyond the minimum service efficiency required in Part L.

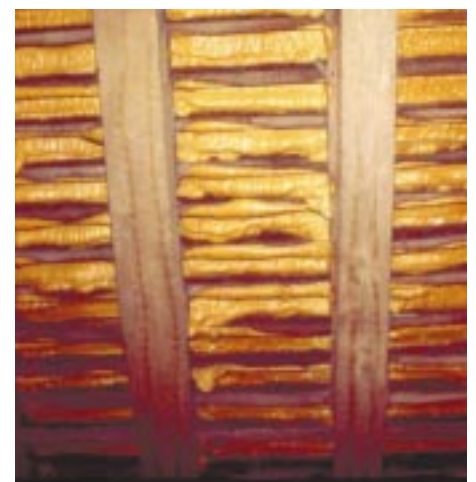

Figure 14 Sprayed foam used as a way of avoiding stripping a 'nail sick' roof and providing some insulation is NOT recommended good practice on a historic building. (Photograph courtesy of Kevin Stubbs, Bursledon Brickworks Conservation Centre)

The last twenty years have seen significant advances in efficiency (e.g. of boilers, lamps and controls) and the replacement cost of old inefficient equipment can often be quickly recovered in fuel cost savings.

13.2 Physical installation

Fitting and replacement of services installations must be done carefully, avoiding unnecessary damage to the historic fabric by short-lived services elements and observing the principles of reversibility and minimum intervention. This relates not only to holes, chases, and fixings, but also to the direct and indirect damage to historic objects by the proximity of services, for example by:

- covering up or interrupting the view of important features and details
- passing too close to important surfaces (e.g. of plaster or panelling) which might be consequentially damaged in the course of the work or in use afterwards (e.g. from dirt traps and/or from cleaning behind pipe lagging run close to surface)
- staining by patterns of heat and air movement
- disturbance of the heat and moisture balance leading, for example, to crystallisation of salts in walls and damage to details and surface finishes.

Constraints of this kind may affect the choice of options and consequently their energy efficiency levels. For example, it might not be possible to replace a conventionally-flued heater with a more efficient balanced-flue version because of the destruction caused by the hole, the visual appearance of the outdoor terminal, or the technical risks of disturbing a rubble-filled wall.

13.3 Heating

Historic buildings have tended not to be heated to the high air temperatures typical in modern buildings. For some of today's uses (e.g. residential and commercial), occupiers will expect modern standards. For other uses, for example in buildings on display to the public, less heating will often be appropriate. Consideration should be given to the use of low temperature radiant heat sources, as these can provide comfort at lower air temperatures.

Part L states that 'buildings or parts of buildings with low levels of heating or no heating do not require measures to limit heat transfer through the fabric', and suggests 25 W/m² as a typical threshold below which this Requirement might apply. This clause will be relevant to many unheated historic buildings; and to others, e.g. historic house museums, country houses, etc in which low levels of background or 'conservation' heating

(Staniforth and Hayes, 1989) may be used, principally for the control of moisture and protection of the fabric, decorative and fine art, furniture and fittings.

13.4 Hot water

In most cases, good practice standards of hot water systems installation will apply equally to new and to historic buildings. Two points may however be made:

- Some large historic buildings have sprawling systems. When alterations are being carried out, an attempt should be made to simplify them, reducing the lengths of pipe runs, improving insulation, and possibly installing more local water heaters.
- When taps, shower heads, etc are being renewed, replacements should be sought which are economical in their use of hot water.

13.5 Air conditioning

Air conditioning is sometimes introduced in museums housed in historic buildings to help conserve objects on display. (Energy-efficient design of air conditioning systems is beyond the scope of this document.) Building owners should always consider if air conditioning is really necessary – sometimes simpler control of the environment is possible, for example to control pollution (as outlined in Blades *et al*, 2000). If air conditioning is specified, care is required not only to minimise the physical damage caused by installation but also to consider the potential deleterious effect of the air-conditioned environment on the building fabric. For example, it is common for air-conditioned museums to include humidification. This additional moisture may condense on the surface of single glazing,

within the fabric, or in unheated parts of the building, causing extensive and long-term damage. (See CIBSE 1998, and revised CIBSE Guide [in preparation].)

13.6 Lighting

As with hot water, it is tempting to ignore lighting energy efficiency in a historic building and to install what is felt to be aesthetically best (often thought to be incandescent tungsten filament lighting). However, while there can be good reasons for this – and incandescent is the oldest form of electric lighting – most historic buildings pre-date it and it would have been installed first as an innovation. It is important to review the balance between aesthetic and efficiency criteria and to develop an appropriate solution in the circumstances. Tungsten may be the correct choice where illuminance levels are low and the lighting is used infrequently. However, the use of more energy-efficient and long-life lamps should be investigated, as this reduces replacement costs as well as energy consumption.

14 Forthcoming advice

The Building Conservation and Research Team of English Heritage is currently preparing a brief for a more detailed *Guidance Note*. This will provide:

- information on traditional materials used in constructing and repairing historic buildings
- best practice examples of benign upgradings
- case studies showing schemes implemented since the new Part L became effective on 1 April 2002.



Figure 15 Examples of early cast iron stove and radiator which are still in use. Items such as these should continue to be used and if necessary refurbished to improve efficiency. (Photograph of stove courtesy of Robyn Pender; photograph of radiator by Chris Wood)

References

Abbreviations

BRECSU	<i>The Building Research Energy Conservation Support Unit of the (former) Building Research Establishment (now BRE Sustainable Energy Conservation)</i>
CIBSE	<i>The Chartered Institution of Building Services Engineers</i>
DEFRA	<i>Department of the Environment, Food, and Rural Affairs</i>
DETR	<i>Department of the Environment, Transport and the Regions</i>
DNH	<i>Department of National Heritage</i>
DoE	<i>Department of the Environment</i>
DTLR	<i>Department for Transport, Local Government and the Regions</i>
LSA	<i>The Lead Sheet Association</i>
SPAB	<i>The Society for the Protection of Ancient Buildings</i>

Blades, N, Oreszcyn, T, Bordass, W, and Cassar, M, 2000 Guidelines on pollution control in heritage buildings, in *Supplement to Museum Practice*, 15 November 2000

BS 7913, 1998 *Guide to the Principles of the Conservation of Historic Buildings*, London: British Standards Institution

CIBSE, 1998 Guide F, *Energy efficiency in buildings*, London: Chartered Institution of Building Services Engineers [See following reference for working title of revised Guide, now in preparation.]

—, **in preparation** *Energy efficient building services and fabric for historic buildings: a good practice guide for historic and traditional buildings*

Clark, K, 2001 *Informed conservation: understanding historic buildings and their landscape for conservation*, London: English Heritage

DEFRA and DTLR, 2001 *Limiting thermal bridging and air leakage: robust construction details for dwellings and similar buildings*, London: The Stationery Office

DETR, 2000 *The Building Regulations 2000, Approved Document Part F: F1 Means of ventilation, F2 Domestic buildings, F3 Non-domestic buildings, and F4 Condensation in roofs (should be read in conjunction with Amendments 2000 to the Approved Documents)*, London: The Stationery Office (See also www.safety.dtlr.gov.uk/bregs/brads.htm and after the transfer of responsibility to the Office of the Deputy Prime Minister, www.odpm.gov.uk and e-mail address bregsb.br@odpm.gsi.gov.uk)

DNH and DoE, 1994 See PPG 15, 1994

DTLR, 1998 *The One Stop Shop Approach to Development Consents*, available www.infoshop.org.uk

—, **2001** *The Building Regulations 2000, Approved Document L1: Conservation of fuel and power in dwellings*, 2002 edition, and *Approved Document L2: Conservation of fuel and power in buildings other than dwellings*, 2002 edition, Department for Transport, Local Government and the Regions, London: The Stationery Office (See also www.safety.dtlr.gov.uk/bregs/brads.htm and after the transfer of responsibility to the Office of the Deputy Prime Minister, www.odpm.gov.uk and e-mail address bregsb.br@odpm.gsi.gov.uk)

Energy Efficiency Best Practice Programme *Good Practice Guide 155: Energy efficient refurbishment of existing housing*, available from BRECSU, Garston, Watford, WD25 9XX, and downloadable from www.energy-efficiency.gov.uk

English Heritage, 1994 *Draughtproofing and Secondary Glazing*, leaflet 1 in the Framing Opinions Campaign leaflet series, London: English Heritage (All the published leaflets in this series are downloadable from www.english-heritage.org.uk [see *Publications: list of free publications*] Print copies can be obtained from English Heritage Customer Services at the address shown in **Further information** below.)

—, **1994** *Window comparisons*, leaflet 5 in the *Framing Opinions Campaign* leaflet series, London: English Heritage

—, **1994** *Energy savings*, leaflet 7 in the *Framing Opinions Campaign* leaflet series, London: English Heritage

—, **1997** *Metal windows*, leaflet 3 (revised) in the *Framing Opinions Campaign* leaflet series, London: English Heritage

—, **1997** *Timber sash windows*, leaflet 4 (revised) in the *Framing Opinions Campaign* leaflet series, London: English Heritage

—, **and LSA, 1997** *Lead roofs on historic buildings: an advisory note on underside corrosion*, London: English Heritage and the Lead Sheet Association (Downloadable from www.english-heritage.org.uk [see *Publications: list of free publications*] Print copies can be obtained from English Heritage Customer Services at the address shown in **Further information** below.)

Hughes, P, 1986 *The need for old buildings to 'breathe'*, Information Sheet 4, SPAB News, 7, no 2, Spring 1986, London

—, **1988** *Patching old floorboards*, Information Sheet 10, SPAB News, 9, no 3, Summer 1988: London

LSA, 1990–1993 *The Lead Sheet Manual: a guide to good building practice*, 1 *Lead sheet flashings* (1990), 2 *Lead sheet roofing and cladding* (1992), 3 *Lead sheet weatherings* (1993), Tunbridge Wells: Lead Sheet Association

PPG 15, 1994 Planning Policy Guidance Note *Planning and the Historic Environment*, Dept of the Environment, Dept of National Heritage; London, Her Majesty's Stationery Office (after 1996 The Stationery Office)

Staniforth, S, and Hayes, R, 1989 Keep the old piles standing, *New Scientist*, No 1678, 19.8.1989, 37–41

Stirling, C, 2002 *Thermal insulation: avoiding risks*, 3 edn, London: CRC Ltd for the Building Research Establishment

Acknowledgements

The authors of this text were Chris Wood (*Building Conservation and Research Team, English Heritage*), and Tadj Oreszczyn (*Professor of Energy and Environment, The Bartlett School of Postgraduate Studies, University College London*). Significant contributions were provided by Dr William Bordass (*William Bordass Associates*), May Cassar (*Director, The Centre for Sustainable Heritage, University College London*) and Oliver Palmer (*Advisor on Building Legislation, Safety and Standards, and Specialist Practice Consultant [Building Regulations] to the Royal Institute of British Architects*).

The authors were assisted in their drafting by a panel drawn from the following organisations

The Royal Institution of Chartered Surveyors' Building Control Forum, represented by David Welsh (*Assistant District Surveyor (North), City of Westminster*) and Peter Lilley (*Building Control Officer, Derbyshire Dales District Council*)

The Institute of Historic Building Conservation, represented by John Preston (*Conservation and Design Officer, Cambridge City Council*), Dr Sarah Higgins (*Conservation Officer, Tewkesbury District Council*) and David Macdonald (*Principal Conservation and Design Officer, Royal Borough of Kensington and Chelsea*)

The Royal Town Planning Institute, represented by Keith Laidler (*Director of Planning, City of Lincoln Council*)

The Department of Transport, Local Government and the Regions, represented by Steve Irving of FaberMaunsell, lead contractor to DTLR Building Regulations Division for reviewing Part L

Contributions were also received from

The Building Regulations Advisory Committee (Working Party for Part L)
The District Surveyors' Association
The Association of Consulting Approved Inspectors
The Royal Town Planning Institute

English Heritage is grateful for their cooperation and assistance.

Further information

English Heritage is the Government's statutory advisor on archaeology and the management of the historic environment in England. English Heritage provides expert advice to the Government about all matters relating to the historic environment and its conservation.

Initial enquiries about local cases should be made to the local authority's Building Control Officer or Conservation Officer. E-mail enquiries about topics discussed in this *Interim Guidance Note* can be made to **brpartl@english-heritage.org.uk**

For further information (and other copies of the print version of this leaflet, **quoting the Product Code – 50675**) please contact:

English Heritage

Customer Services Department
PO Box 569
Swindon
SN2 2YP
Telephone: 0870 333 1181
Fax: 01793 414926
E-mail: customers@english-heritage.org.uk

We also have nine regional teams, which can be contacted at:

London Region

23 Savile Row
London
W1S 2ET
Telephone: 020 7973 3000

South East

Eastgate Court
195–205 High Street
Guildford
GU1 3EH
Telephone: 01483 252000

South West

29–30 Queen Square
Bristol
BS1 4ND
Telephone: 0117 975 0700

East of England

Brooklands House
24 Brooklands Avenue
Cambridge
CB1 1DJ
Telephone: 01223 582700

East Midlands

44 Derngate
Northampton
NN1 1UH
Telephone: 01604 735400

West Midlands

112 Colmore Row
Birmingham
B3 3AG
Telephone: 0121 625 6820

North East

Bessie Surtees House
41–44 Sandhill
Newcastle upon Tyne
NE1 3JF
Telephone: 0191 269 1200

North West

Suites 3.3 and 3.4
Canada House
3 Chepstow Street
Manchester
M1 5FW
Telephone: 0161 242 1400

Yorkshire

37 Tanner Row
York
YO1 6WP
Telephone: 01904 601 901



a



b

Figure 16 The heat loss from this listed public house has been dramatically reduced by the installation of discreet secondary glazing (b) and (c). The glazed panels can be easily removed in summer. (Photographs courtesy of Storm Windows, Leeds, © copyright Storm Windows, Leeds)



c

Published September 2002
© English Heritage 2002

English Heritage website
www.english-heritage.org.uk

Editing for English Heritage website
presentation, May 2002 Robert Gowing
(English Heritage Building Conservation

and Research Team), Amrik Kerketta
(English Heritage Web Team)
Editing for press Margaret Wood
(English Heritage Publications)
Graphics Ray Martin (Art Services),
Dr Robyn Pender
Design Simon Borrough
Production Elaine Pooke
(English Heritage Publications)
Printer Billington Press Ltd

Product Code 50675

Front and back covers: historic facades
and doorways, and historic windows, both
metal (front cover nos 1, 2, and 3; back cover
no 7) and timber framed. (Photographs 1
and 7 courtesy of Jill Channer, copyright ©
Jill Channer; 2, 3, 4, 5, 6 and 8 by Chris
Wood and English Heritage Conservation
and Research Team)



ENGLISH HERITAGE